

FITTING INSTRUCTIONS

Toyota Hilux Extended 04/05 on – T7T703



Max Towing Capacity: 3500Kg	Towbar Weight: Approx. 27Kg
Max Ball Load: 350Kg	...



Tools Required:

M10,12 Spanners/Sockets, Torque Wrench (Torque M10 to 60Nm, M12 to 100Nm)

Kit Contents					
Item No.	Description	Qty	Item No.	Description	Qty
1.	Towbar centre section	1	10.	M12 Flat Washer	22
2.	Towbar End Plate Passenger Side	1	11.	M12 Shake Proof Washer	14
3.	Towbar End Plate Drivers Side	1	12.	M12x1.25x45 Bolt	14
4.	M12x1.25 Nut Plate on Wire	2	13.	M12x1.25 Nut	8
5.	Dual Slot Top Plate	2	14.	Class 4 Pin & Clip	1
6.	M10x1.5x30 Bolt	4	15.	3mm Spacer	2
7.	M10 Flat Washer	4	16.	Hitch Collar Cover	1
8.	M10 Shake Proof Washer	4	---	D-Shackles	2
9.	M10x1.5 Nut	4	---	Compliance Sticker	1

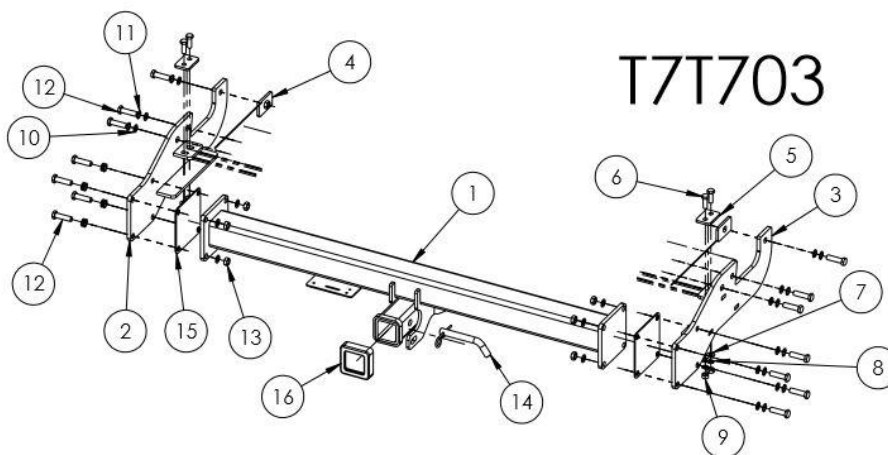

Warning:

- This product is for towing purposes only and must only be loaded as shown in your vehicle Owners Manual.
- This towbar is NOT to be drilled, cut, welded or modified in any way.
- Check behind chassis rail and body panels before drilling to ensure no hazards are present

General:

- Before fitting this towbar read fitting instructions and check installation hardware is correct.
- Check that the towbar is suitable for the vehicle and be wary of any changes to the vehicle design that may conflict with the fitting of this towbar.
- After drilling, blow any filings clear, remove any swarf and treat exposed metal with a rust inhibitor.
- If this vehicle requires a bumper cut out, please check to make sure that you measure twice and check twice before cutting any panels as some bumper profiles can change. If you are not sure, then please ask your towbar supplier

FITTING INSTRUCTIONS

Toyota Hilux Extended 04/05 on – T7T703



Step 1 Attach Towbar End Plates



Instructions	Tools	Fasteners/Torques
<p>Loosely secure both towbar end plates to the chassis.</p> <ul style="list-style-type: none"> - Using 2x M12x35 Bolts, Flat and Shake Proof Washers in the rearward 2 holes on outside of each chassis rail - Using 1x M12x35 Bolt, Flat and Shake Proof Washers into the M12 Nut Plate on Wire, through the hole towards the front of the vehicle in each chassis rail (bend wire and tuck into chassis rail) - Using 2 x M10 Bolt, Flat and Shake Proof Washer and the Dual Hole Top Plate through the mounting point on the bottom of each chassis rail. <p>Tighten the bolts to hold the end plates against the chassis rails. DO NOT tighten to torque spec.</p>	<p>-M10, M12 Spanners and Sockets</p>	<p>N/A</p>

Step 2 Determine if Spacers are required



Instructions	Tools	Fasteners/Torques
<p>Position the Towbar centre section between the two end plates.</p> <p>If there is more than approx. 3mm clearance between the parts on each side, then spacers will be required.</p> <p>If the clearance is less than this, spacers will not be required between the parts.</p>	<p>N/A</p>	<p>N/A</p>

FITTING INSTRUCTIONS

Toyota Hilux Extended 04/05 on – T7T703



Step 3 Secure Towbar Centre Section and Torque Bolts

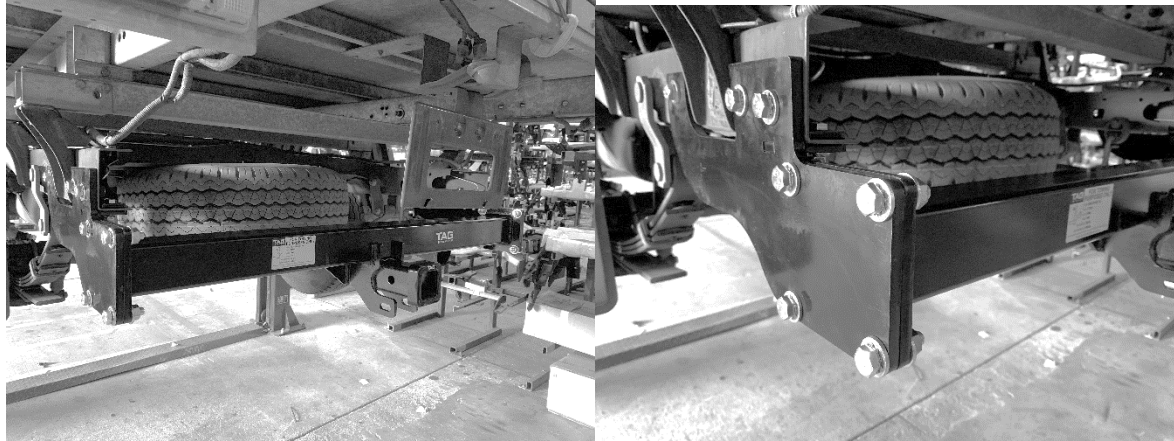

Instructions	Tools	Fasteners/Torques
<p>Using 4x M12x45 Bolts, Shake Proof Washers and Bolts, 8x M12 Flat Washers, and 1x Spacer (if required) per side. Loosely secure the towbar centre section between the end plates. Ensure centre section is right side up with the hitch receiver bellow the main cross-bar.</p> <p>When all hardware is in place, tighten all bolts (including those into the chassis rails) to the torque specified.</p>	<p>-M10, 12, 14 Spanners and Sockets -Torque Wrench</p>	<p>M10 = 60Nm M12 = 100Nm</p>

Step 4 Apply Sticker to Door Jam



Instructions	Tools	Fasteners/Torques
<p>Apply Towbar info label to the inside of the driver's side door Jam.</p>	<p>N/A</p>	<p>N/A</p>

FITTING INSTRUCTIONS

Toyota Hilux Extended 04/05 on – T7T703



WARRANTY STATEMENT

The manufacturer of TAG branded products, warrants your TAG Towbar for its full product life under the following conditions:

- You can show proof of purchase.
- The towbar has been correctly installed by a suitably qualified installer.
- The towbar has not been modified or abused in any way and has only been used for the purpose intended.
- The towbar was not fitted second hand to your vehicle.

The extent of this warranty includes materials and workmanship used in the manufacture of the towbar and is to the equivalent value of current, full replacement cost.

Nothing stated or implied in this warranty limits in any way, the statutory rights that you may have.

To make a claim visit the original installer in the first instance or, if you are unable to or are not satisfied with their help, then contact us direct by phone on 07 3208 3022 or via email qldsales@arandatowbars.com.au