



SAFARI R-SPEC SNORKEL

SS78RZ

01/04/15

ITEM	DESCRIPTION	QTY	PART NO.
1	BODY – SNORKEL	1	330-133-600R
2	3 ½” AIR RAM ASSEMBLY	1	000-135-800
3	BRACKET - UPPER MOUNTING	1	330-032-200
4	BOLT - HEX 6mm x 1.0mm x 14mm	2	000-002-100
5	SCREW - S/T 4.2mm x 13mm – S/S	3	000-951
6	BODY CLIP - PLASTIC	3	000-960
7	STUD - S/S 8mm x 1.25mm x 25mm O/L	4	000-110
8	WASHER - BODY 8mm x 30mm – S/S	4	000-311-300
9	NUT - NYLOC 8mm x 1.25mm – S/S	4	000-205-300
10	CLAMP - HOSE 70/90mm	1	000-908
11	HOSE - AIR ENTRY	1	330-024-000
12	TEMPLATE	1	330-017-600
13	HOSE CLAMP - SIZE 56 (BLACK)	1	000-914/B



SAFARI R-SPEC SNORKEL

SS78RZ

TOYOTA LANDCRUISER HZJ 75/78 SERIES 4.2 DIESEL (1HZ Engine)

Fitment to:	Right hand side
Fitting time:	Approximately 120 minutes
Special Tools:	89mm Holesaw Step Drill Touch-up Paint Air Hacksaw Loctite 243 (thread lock)

Prior to commencing the installation, it is the installer's responsibility to verify that all components and particularly the template (Item 12) are correct.

Instructions:

1. Remove: Air cleaner assembly
Standard air entry ducting
Fuel filter assemblies
Landcruiser badge
2. Tape the template to the rear edge of the guard and the extended part of the template to the top edge of the guard. Using a felt tip pen, mark all hole positions, remove template.
3. Drill a pilot hole for each hole position. Using the step drill, drill the 4 snorkel mounting hole positions to 16mm. Using the 89mm holesaw, drill the 2 main hole positions. Mark a straight line top and bottom of the holes. Using the air hacksaw, cut away the remaining pieces of the panel. Deburr and paint holes.

4. Install the upper mounting bracket (item 3) to the snorkel body (item 1) with hex bolts (item 4). Apply Loctite 243 to each of the stainless steel mounting studs (item 7) and install the studs finger tight into the snorkel body (item 1) mounting inserts.
5. Carefully position the snorkel body onto the guard. With the snorkel body correctly positioned onto the guard, mark the 3 upper mounting bracket hole positions on the 'A' pillar. Remove the snorkel body.
6. Drill the 3 marked holes on the 'A' pillar to 8mm, deburr and paint holes. Insert plastic body clips (item 6) into the 'A' pillar.
7. Position snorkel body onto the guard. With the snorkel body correctly positioned, fasten using necessary hardware. Fasten the upper mounting bracket to the 'A' pillar.
8. Position hose clamp (item 10) onto the snorkel body snout. With the hose clamp in position install air entry hose (item 11) to the snorkel body snout (a small amount of lubricant may be required at each end of the hose to ensure easy fitment). With the hose correctly positioned fasten the hose clamp.
9. Re-install fuel filter assemblies and air cleaner assembly to the vehicle. Fasten the air entry hose to air cleaner using the standard hose clamp.
10. Install air ram assembly to the snorkel body and fasten.

N.B: It is the installer's responsibility to ensure that all connections are watertight.

SAFARI

4X4 ENGINEERING

Model No: **SS78RZ** 11.04.00
Description: TOYOTA LANDCRUISER 75/78 SERIES 4.2L DIESEL (1HZ ENGINE)
Sub Assembly: SAFARI SNORKEL

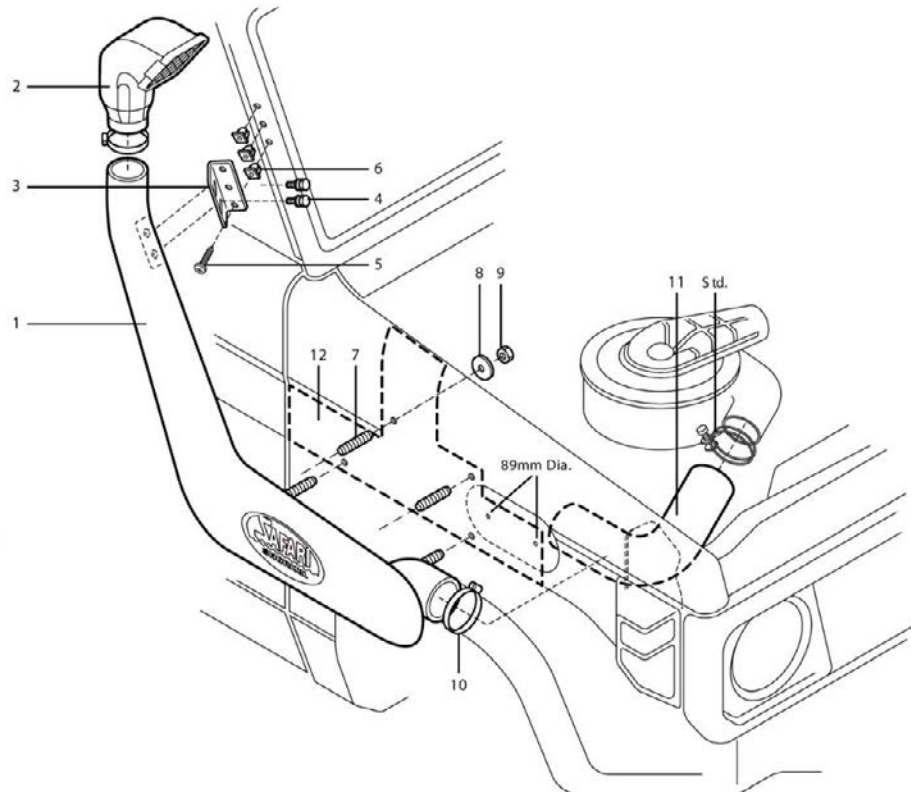

NOTE:
It is the Installer's responsibility
to ensure all connections
are water tight.