



# HITCH INSTALLATION INSTRUCTIONS

**MAKE:** BMW      **YEARS:** 2022 - 2023      **MODEL/TRIM:** iX xDrive 50  
 2023      iX M60

www.stealthhitches.com 833-694-4824

RACK RECEIVER KIT#: **SHR31040**

COMPATIBLE WITH TOW KIT: **SHT25061**



**2" RACK RECEIVER MAXIMUM PAYLOAD:** 600 LBS  
**MAXIMUM TOW RATING:** 6000 LBS  
**MAXIMUM TONGUE WEIGHT:** 600 LBS

## UNDER VEHICLE TRIMMING:

HEAT SHIELD: **NO**  
 FASCIA: **YES**  
 GRAVEL GUARD TRIMMING: **NO**



**READ ALL INSTRUCTION WARNINGS AND LABELS**



**NO WELDING, METAL DRILLING OR VISIBLE TRIMMING REQUIRED**

## PARTS SUPPLIED WITH RACK RECEIVER KIT:

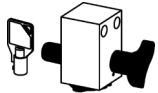

LATCH BLOCK & KEYS



(2) BOLTS  
5/8" - 11 x 5"



(2) 5/8"  
NYLOCK NUTS



(1) M6 SERRATED  
FLANGE NUT



2" RACK  
RECEIVER

## ADDITIONAL PARTS FOR TOW KIT:



BALL MOUNT  
5" RISE, SHORT



CHAIN HOOKS



2" BALL

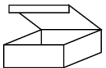

PASSIVE WIRING  
KIT BOX

## TOOLS REQUIRED:



10mm & 15/16"  
OPEN  
END WRENCH



18mm DEEP WELL,  
8mm, 10mm, 12mm  
& 15/16" SOCKETS



TORQUE  
WRENCH

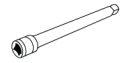

SOCKET  
EXTENSION



RATCHET



FLASHLIGHT



DREMEL TOOL



90 DEGREE  
PICK



SAFETY GLASSES



PLASTIC  
PRY TOOLS



FILE



T30 TORX

## ADDITIONAL TOOLS FOR TOW KIT:



PLIERS



STRIPPER/  
CRIMPING  
TOOL



MULTIMETER



PHILLIPS HEAD  
SCREWDRIVER



DRILL &  
3/8" BIT



SILICONE



T20 TORX



FISH  
WIRE

**RACK RECEIVER INSTALLATION:** USE STEPS 1-16 & 49-53  
**TOW KIT INSTALLATION:** USE STEPS 1-53

# <THESE INSTRUCTIONS MUST BE GIVEN TO THE END USER>

**NOTICE:** Installation of Stealth products may or may not require the addition of a wiring harness to the vehicle.

- The Rack Receiver only product does not require adding a wiring harness.
- The Rack Receiver plus Tow Kit requires the addition of a "Passive" wiring harness to the vehicle. The passive harness "reads" the output of the vehicle's lights and translates the signals to the trailer without being connected to the vehicle computer.

**INSTALLATION NOTE:** In most instances, these instructions will only outline disassembly of vehicle components. Re-installation of components will require the installer to retain vehicle hardware and work through disassembly instructions in reverse order. When installation is complete, double check that all vehicle components have been replaced and are secured.

## IMPORTANT SAFETY NOTICE FOR STEALTH HITCH INSTALLERS AND CUSTOMERS.

Read all installation and operating instructions along with all labels before installing or using this product. Do not perform any installation or towing procedures without fully understanding the correct tools and actions for all steps. Call for support if needed.

### **⚠ WARNING** Failure to comply with the safety information in these instructions could result in serious injury or death.

- ⚠ Do not modify this product in any manner. Doing so could alter its integrity and lead to a loss of attachment between the trailer and the tow vehicle.
- ⚠ Adding Stealth hitch components to the chassis of any vehicle can be hazardous. There is potential for unexpected combustion of fuel, electric shock, burns, shifting or falling of unstable vehicle, damage to vehicle, injury from tool usage and many other hazards. This installation must be completed by someone who is aware of the hazards involved. This person must be knowledgeable of proper safety procedures for a vehicle modification of this nature, and for usage of the equipment required to perform the installation.
- ⚠ Without proper knowledge, towing can be a dangerous activity. Understand all the risks involved with towing before proceeding. For information on towing safety, see "**The Trailer Handbook: A Guide to Understanding Trailer and Towing Safety**" from the National Association of Trailer Manufacturers, [www.NATM.com](http://www.NATM.com) and your trailer and tow vehicle manufacturer's owner's manual.
- ⚠ Do not exceed tow or tongue rating of coupler, tow or tongue rating of hitch, or tow or weight ratings of tow vehicle or trailer. See vehicle and trailer manufacturer information for ratings. Exceeding these ratings may cause damage to towing components or loss of attachment between the trailer and vehicle.
- ⚠ While installation is being performed, check for signs of damage or excessive corrosion. Do not install hitch components over vehicle parts that are broken or have compromised structural integrity.
- ⚠ This product was designed to fit vehicles in their original, "as manufactured" condition. Compatibility with vehicles having replacement parts, or other modifications is not guaranteed. Inspect vehicle for modifications before installation of this product.
- ⚠ Some accessories, like the rack receiver, are not rated for towing. Do not use any accessories without proper knowledge of their use.
- ⚠ A visual inspection of the hitch should be performed before each use. Regularly check that all connections are secure, including those that secure the hitch to the vehicle. Check for cracks or damage to the hitch. Do not use the hitch if cracks or damage outside of normal wear is found. Using a hitch that has unsecure connections and/or cracks or damage could result in damage to the tow vehicle, trailer, towing components and loss of attachment between the tow vehicle and trailer.
- ⚠ Stealth hitches are not compatible with any weight distribution or sway control products. Adding additional products to the trailer or chassis which modifies the function of the Stealth hitch may cause hitch failure.

**NOTICE:** Installation of hitch requires removal of vehicle parts and interaction with vehicular electronics. Before installation, check the condition of body panels and note any locations where panels are not flush. Check the electronic functions of the vehicle, such as: headlights, taillights, turn signals, cameras, backup sensors, Parking Distance Controller (PDC), foot activated cargo access, etc. It is the responsibility of the installer to restore the fit and function of the vehicle.

### GAIN ACCESS TO MOUNTING AREA



8mm  
SOCKET

-OR-



10mm  
SOCKET

1. Locate and remove the (4) screws that hold the wheel well liner in place inside the edge of the rear wheel well (yellow arrows). Remove (2) screws on the bottom rear edge of the wheel well behind the tire (green arrows).



PLASTIC  
PRY TOOLS



90 DEGREE  
PICK

2. Fold the flexible liner back toward the tire. Behind the liner locate (1) plastic rivet. Use a 90 degree pick tool or plastic pry tool to remove the rivet. Repeat Steps 1 and 2 on other side of vehicle.



8mm  
SOCKET



10mm  
-or-  
12mm  
SOCKET

3. Under the rear of the vehicle, remove (10) screws and (2) plastic nuts attaching the central underbody panel.

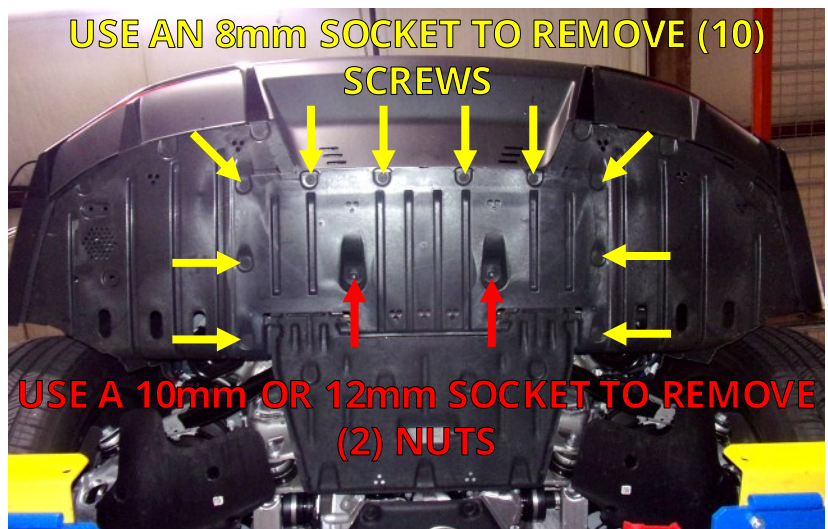

## GAIN ACCESS TO MOUNTING AREA CONTINUED



8mm  
SOCKET



10mm  
-or-  
12mm  
SOCKET

4. Under the rear of the vehicle, remove (5) screws and (2) plastic nuts attaching each underbody side panel.

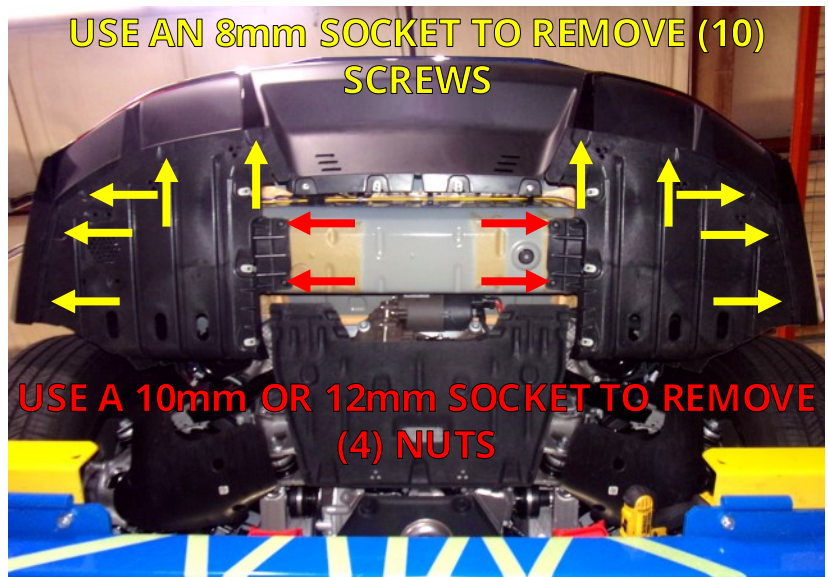

8mm  
SOCKET

5. Locate the two screws in the inside edge of the fascia. Remove each of the (2) screws using a socket.



6. Locate the (2) plastic clips on the outside edge of the fascia directly behind each tire. Use a plastic pry tool to unclip (2) clips on each side of the vehicle.



## GAIN ACCESS TO MOUNTING AREA CONTINUED



7. The rear fascia is clipped to the vehicle body above and behind the wheel wells. Pull outward on the top front of the rear fascia to expose a clip in the seam. With a plastic pry tool, push down on the exposed clip to disconnect. Continue to pull outward on the fascia and disconnect clips as they are exposed. Repeat on other side of vehicle.

**NOTE:** Use caution when pulling the fascia rearward. The fascia is still connected to the vehicle by a wire harness.



8. This step requires a partner. Pull the fascia rearward enough to access the plug on the passenger side and unplug it. Remove the fascia completely.

**NOTICE:** Carefully remove the fascia and place on a blanket or pad.



9. Behind the fascia locate plastic kick wand panel. On the passenger side of the panel unplug the wiring harness which runs to the vehicle. Use a plastic pry tool to remove (6) rivets securing the panel to the factory reinforcement beam. Save (4) of the plastic rivets for reinstallation.



## GAIN ACCESS TO MOUNTING AREA CONTINUED



T30 TORX



18mm  
DEEP WELL  
SOCKET

10. Locate the sensor in the center top of the reinforcement beam. Use a Torx bit to remove (1) screw holding the sensor in place. Save the screw for reinstallation.

11. Use a socket to remove (8) nuts securing the factory reinforcement beam to the vehicle. Discard the beam and save the (8) nuts for reinstallation.

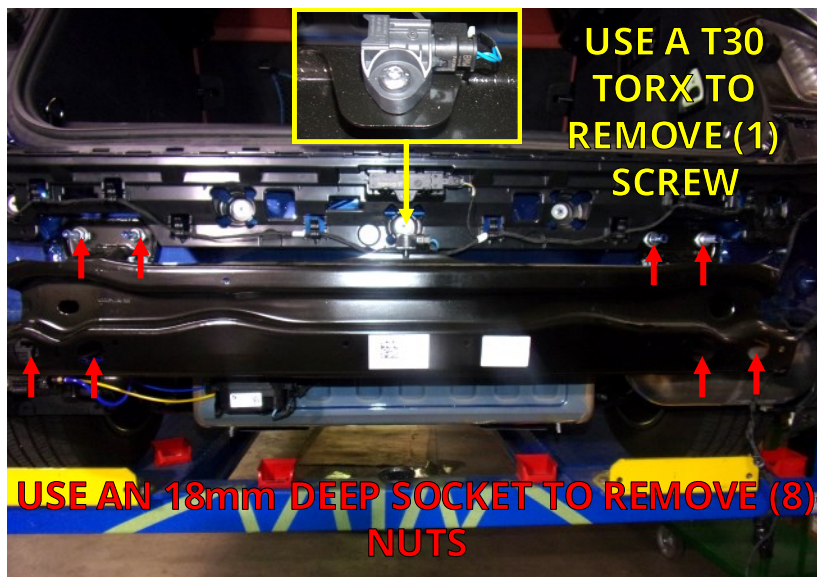

## PREPARE KICK WAND PANEL



DREMEL TOOL



FILE

12. Cut out a section of the kick wand panel with a Dremel tool as shown in the image. Use a file to smooth the edges of the cut.

**NOTICE:** Use caution when cutting the kick wand panel. Do not damage any electrical components or wiring.

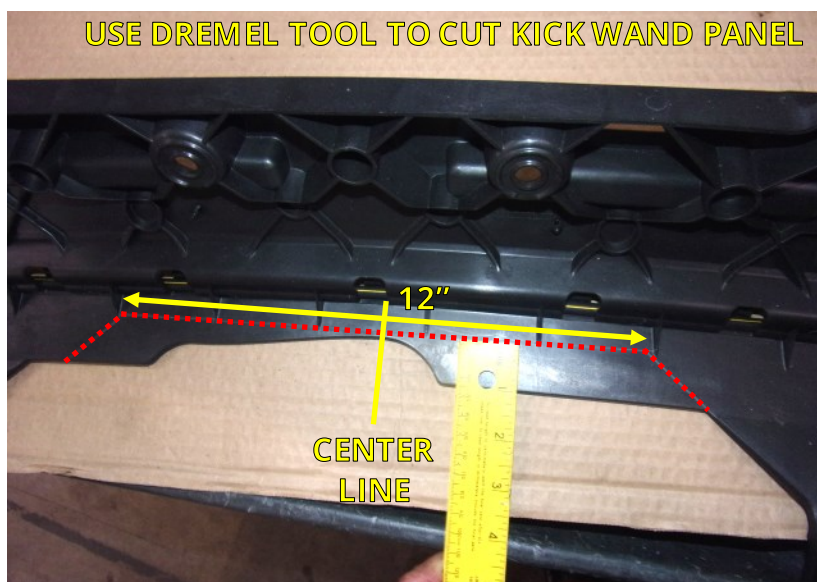

## INSTALL STEALTH HITCH FRAME



18mm  
DEEP WELL  
SOCKET



TORQUE  
WRENCH

13. Install Stealth hitch frame over the studs used for the factory reinforcement beam. Center the hitch frame. Use a torque wrench to tighten the (8) factory nuts to 85 ft.-lbs.

14. Attach the plastic kick wand panel as shown, using (4) saved plastic rivets.

USE 18mm DEEP WELL SOCKET TO INSTALL (8) NUTS

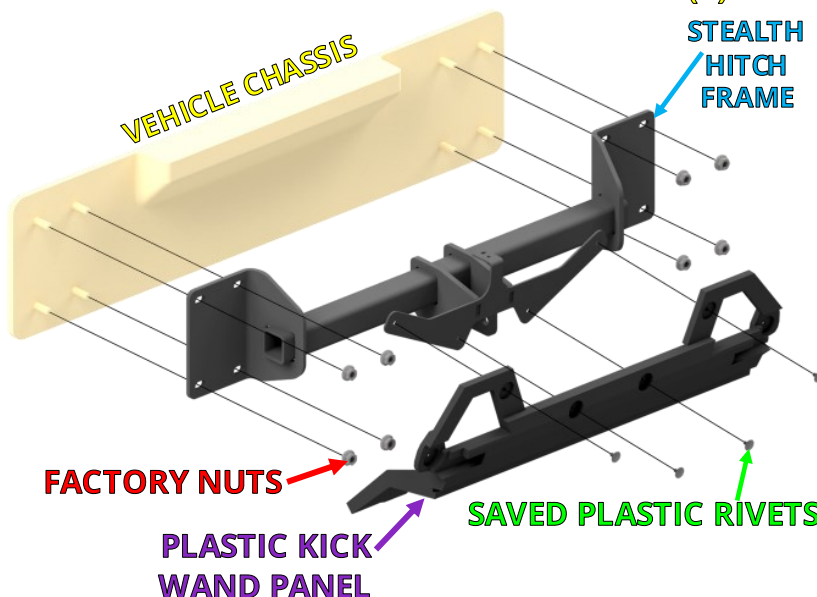



15. Locate the M6 flange nut in the kit box. While reusing the saved sensor bracket screw, replace the sensor which was removed in Step 10. The sensor will mount to the flange located on the top of the Stealth hitch frame.

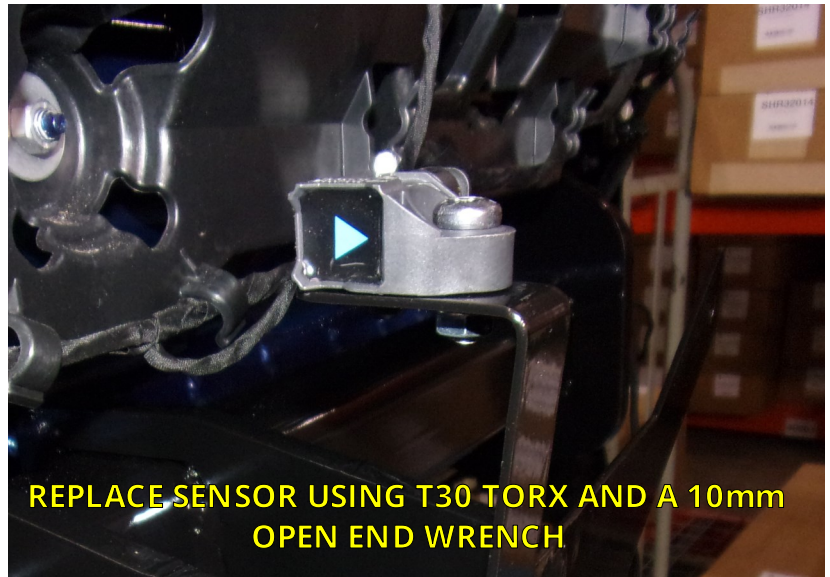

## MOUNT LATCH BLOCK



16. Installation of the latch block varies depending on which kit you are installing.

- **Rack Receiver Kit:** Install the latch block with (2) 5/8"-11 x 5" bolts and (2) 5/8" nylock nuts. Tighten each bolt to 150 ft.-lbs.
- **Tow Kit:** Install the latch block mounting bracket, and (2) chain hooks with (2) 5/8"-11 x 5" bolts and (2) 5/8" nylock nuts. Tighten each bolt to 150 ft.-lbs.

**NOTICE:** Keys are packaged within the latch block, remove keys and store in safe location.

### RACK RECEIVER KIT INSTALL



### TOW KIT INSTALL

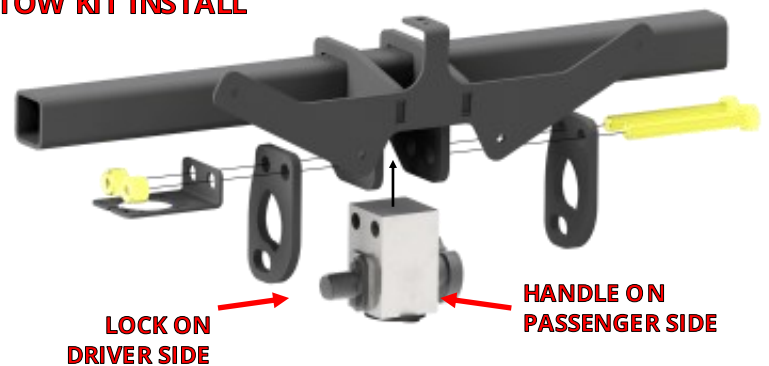

**IF INSTALLING A RACK RECEIVER KIT, SKIP TO STEP 49.  
IF INSTALLING A TOW KIT, CONTINUE TO STEP 17.**

# INSTALL PASSIVE WIRING KIT

#	DESCRIPTION	QTY
1	7-WAY WIRING HARNESS • FUSE HOLDER & FUSE • CONTROL MODULE & WIRES	1
2	ADHESIVE FOAM STRIP	2
3	FORK TERMINAL	1
4	CLAMP-ON CONNECTORS	5
5	5/8" LONG PHILLIPS SCREWS	4
6	#10 LOCK NUT	4
7	M10 SERRATED FLANGE NUT	1
8	BUTT CONNECTOR RED	2
9	CABLE TIE - 8"	8
10	CABLE TIE - 14"	3
11	MOUNTING BRACKET	1
12	7-POLE HOUSING	1
13	7-POLE TO 4-POLE ADAPTER	1
14	GREEN WIRE BUNDLE - 15'	1
15	YELLOW WIRE BUNDLE - 15'	1



17. Locate the wiring kit box. Review the contents of the box against the list above to check for missing components. The passive wiring kit uses a control module to manage the functions of the trailer lighting. The module has an "input" side that receives power from the vehicle's battery and signals from the vehicle's taillights. The "output" side of the module delivers this information to the 7-way plug. The control module is connected to the vehicle's battery and taillight wiring as outlined in the next steps.

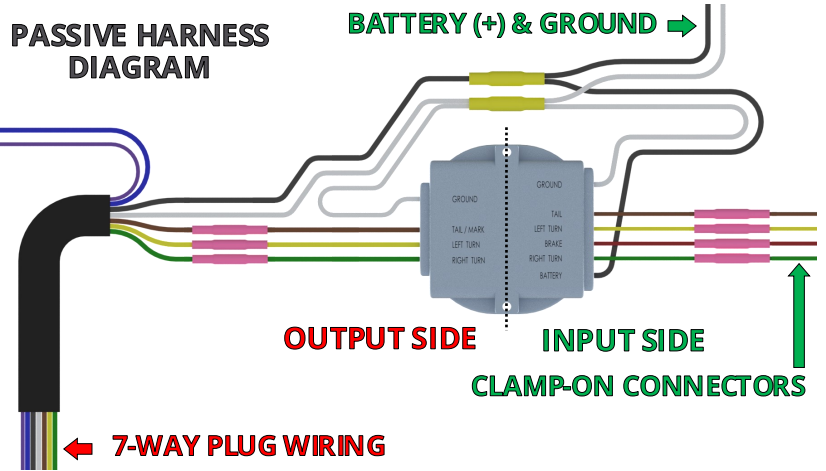

**NOTICE: Do not allow electrical system to become disconnected from power or ground. Doing so may interrupt electrical systems.**

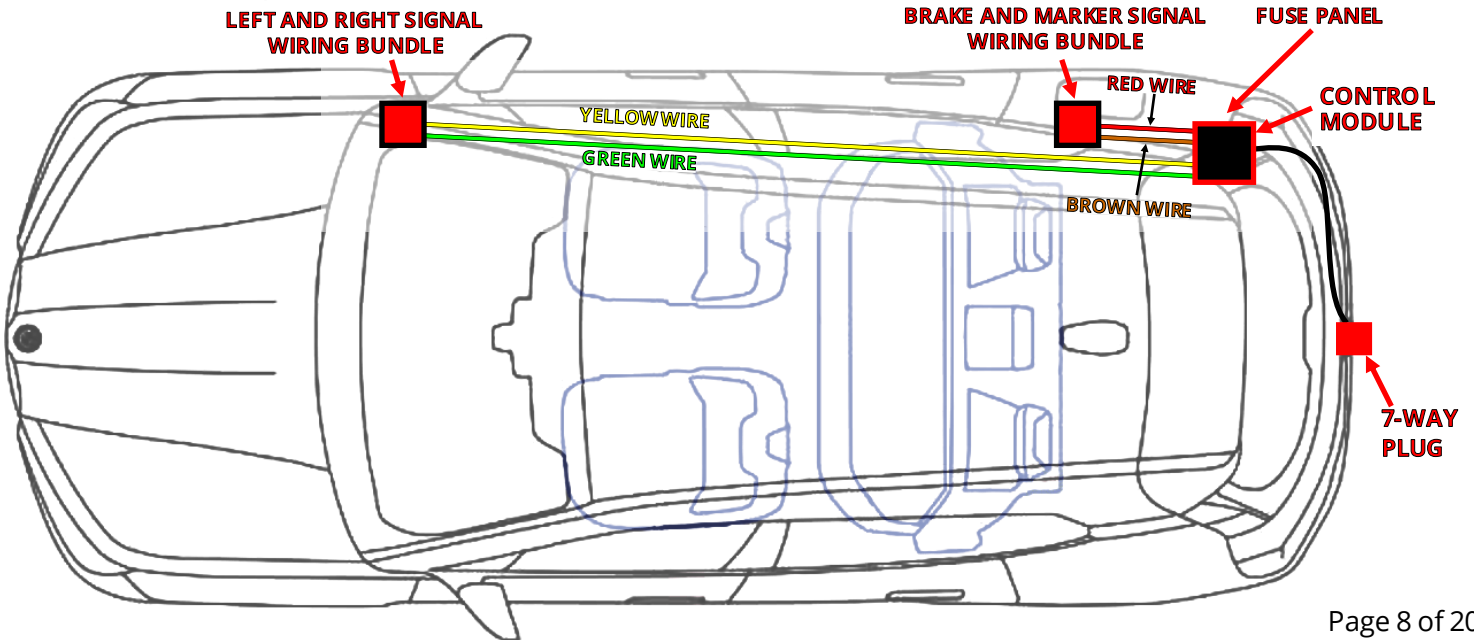



## INSTALL WIRING KIT CONTINUED

18. Open the rear hatch. Inside the cargo compartment, lift up on the floor panel and fold it towards the front of the vehicle.

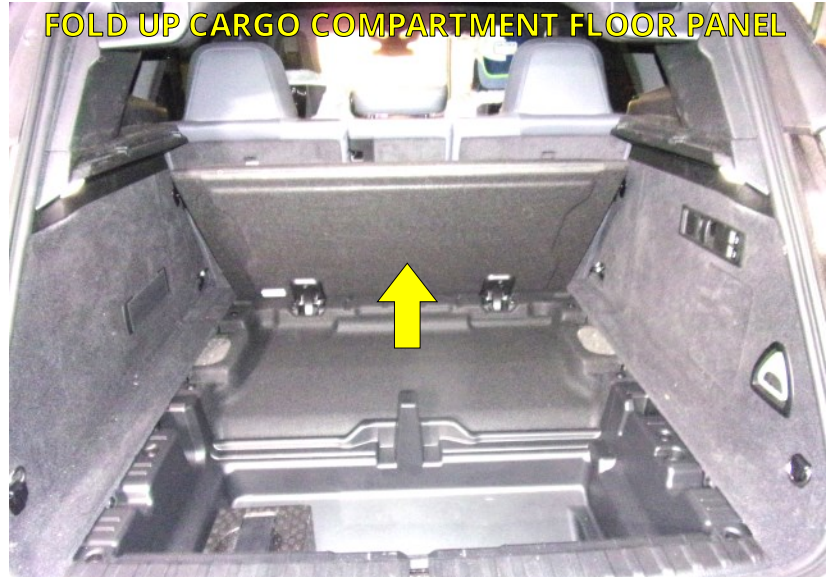

19. Locate (5) plastic rivets along the rear wall of the cargo compartment. Remove these rivets with a 90 degree pick tool. Lift up on the threshold to remove.

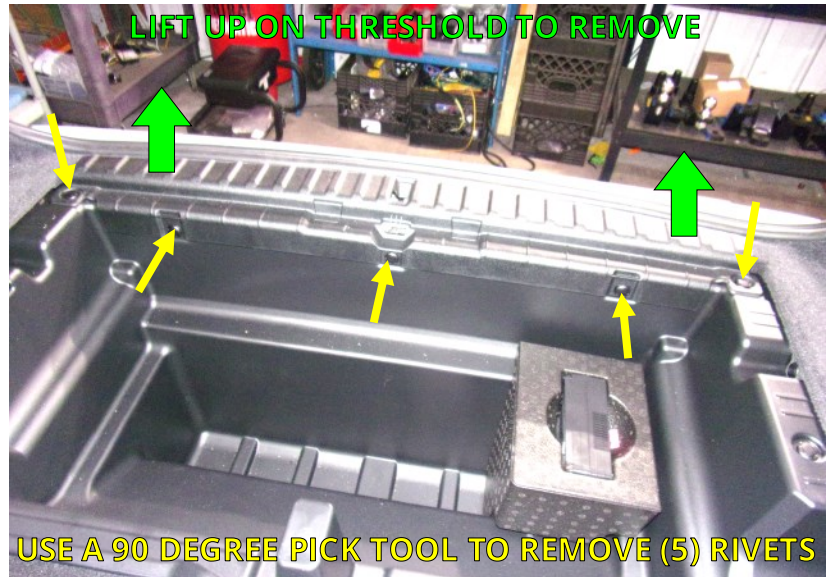

20. On the passenger side cargo compartment side panel, use a 90 degree pick tool to open the cargo anchor cover (yellow arrow). Use a Torx to remove the cargo anchor (green arrow).



## INSTALL WIRING KIT CONTINUED



90 DEGREE PICK

21. Locate (3) plastic rivets securing the bottom of the passenger side panel. Use a 90 degree pick tool to remove the rivets (yellow arrows). Locate the emergency trunk release handle. Remove the pull cable from the handle, then slide the cable through the hole into the area behind the panel (green arrow)



90 DEGREE PICK



T20 TORX

22. On the same panel locate and remove the control panel. Use a 90 degree pick tool to remove the cover and then use a Torx to remove the anchor.



PLASTIC PRY TOOLS

23. Use a plastic pry tool to dislodge the passenger side wall panel. Pull the panel out to gain access to the area behind the panel. Locate (3) connectors and unplug them from the panel. Remove the passenger side panel from the cargo compartment.

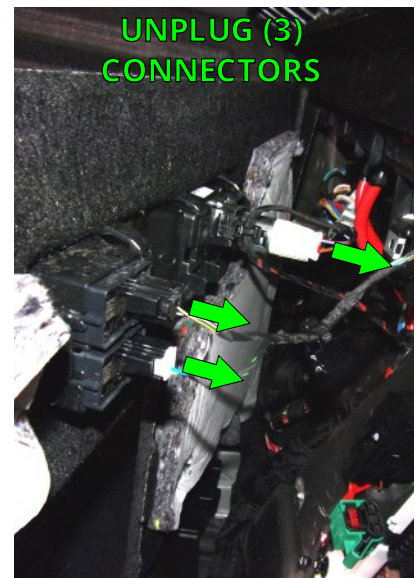
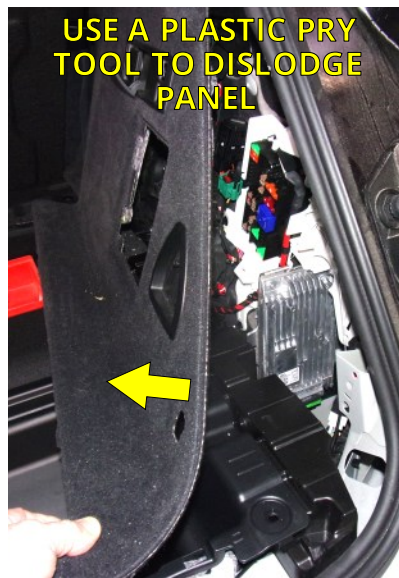

## INSTALL WIRING KIT CONTINUED

24. Retrieve the wiring harness and control module from the wiring kit box. Place the control module inside the passenger side compartment.

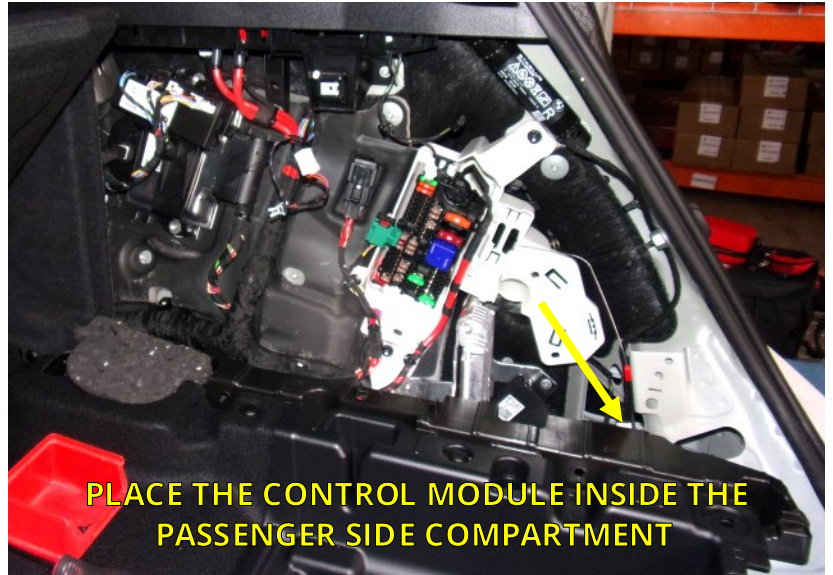

DRILL &  
3/8" BIT

25. Locate rubber wiring harness grommet on the passenger side of the vehicle. Drill a 3/8" hole in the grommet. Make sure to drill through grommet only and not to damage harness.

**NOTICE:** Confirm that there is nothing inside vehicle behind grommet that can be damaged.

26. Feed the 7-way plug wiring and the black sheathing through the grommet from inside of the vehicle to the outside of the vehicle.

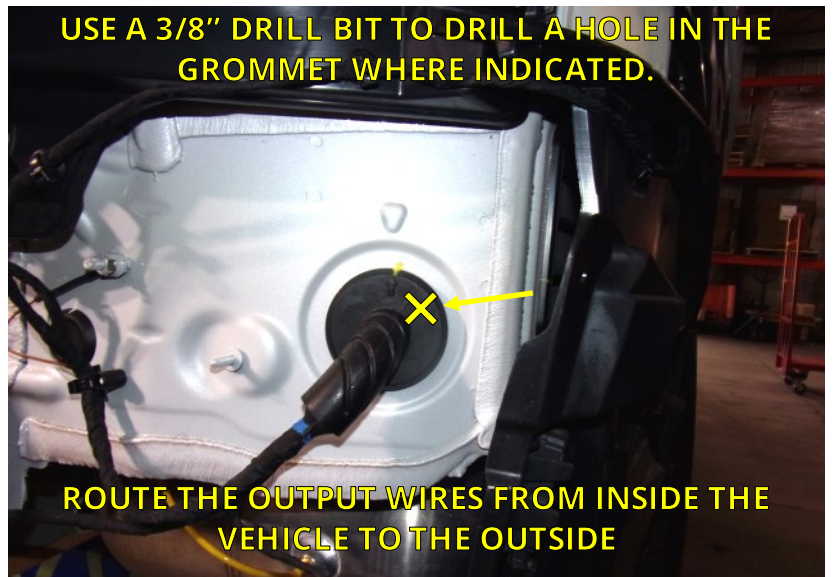

27. The signal wires for the left and right turn signals are located in the front passenger side area of the cabin. Open the passenger side front door. In the area above the foot well, locate and turn two knobs to release the plastic panel shown in the image. Pull the plastic panel down and unplug the light from the panel. Remove the panel from the vehicle.



## INSTALL WIRING KIT CONTINUED



28. Use a plastic pry tool to open and remove the passenger side panel of the dash board.



29. Use a plastic pry tool to remove the plastic door frame panel next to the dash board. The panel is attached with (3) plastic fasteners.

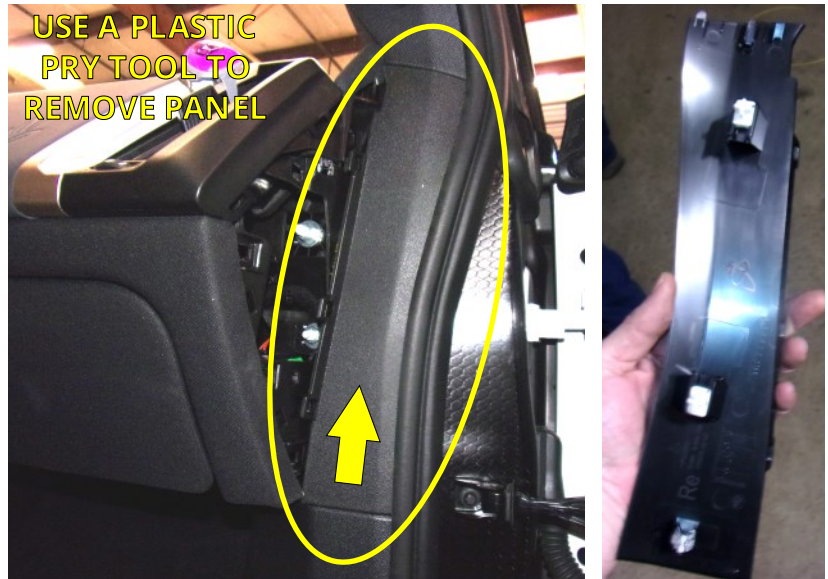

30. Use a plastic pry tool to remove the plastic door frame panel next to the passenger side foot well. First, put inward pressure on the top portion of the panel to disconnect (3) plastic rivets. Second, use upward pressure to disconnect the remaining (4) clips and remove the plastic panel.

**NOTE:** The wire bundle referenced in Step 34 with the left and right turn signal wires is located under this panel.

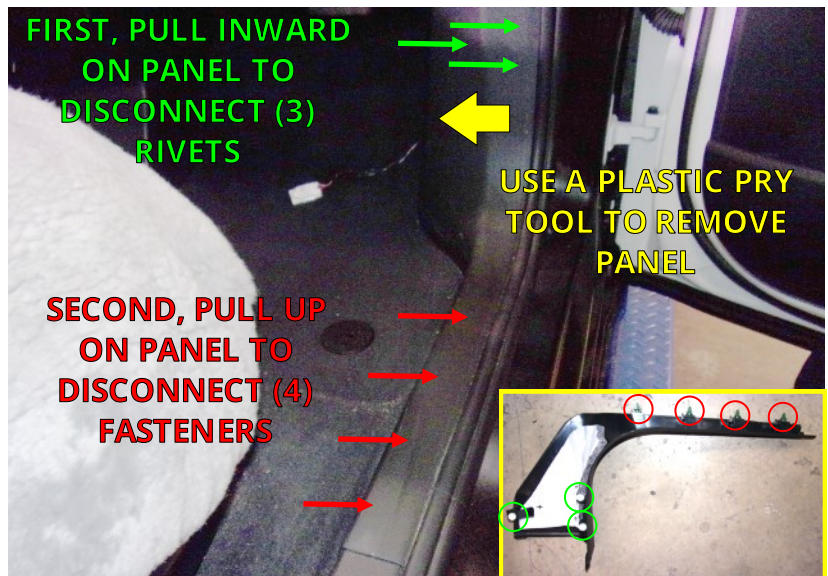

## INSTALL WIRING KIT CONTINUED

31. Open the passenger side rear door. Lower the rear seat. On the side of the cargo compartment wall, locate the grommet shown in the image. Remove the grommet. Use a socket to remove the screw which was under the grommet. With the screw removed pull the trim piece toward the front and remove it from the vehicle.



32. Locate the green and yellow wires inside the wiring kit box. Uncoil the wires. Place the loose wires into the cargo compartment. Place one end of the wires in the space between the passenger side rear seating and the rear door.



33. Using a fish wire pass the green and yellow input wires under the trim next to the rear seating as shown.

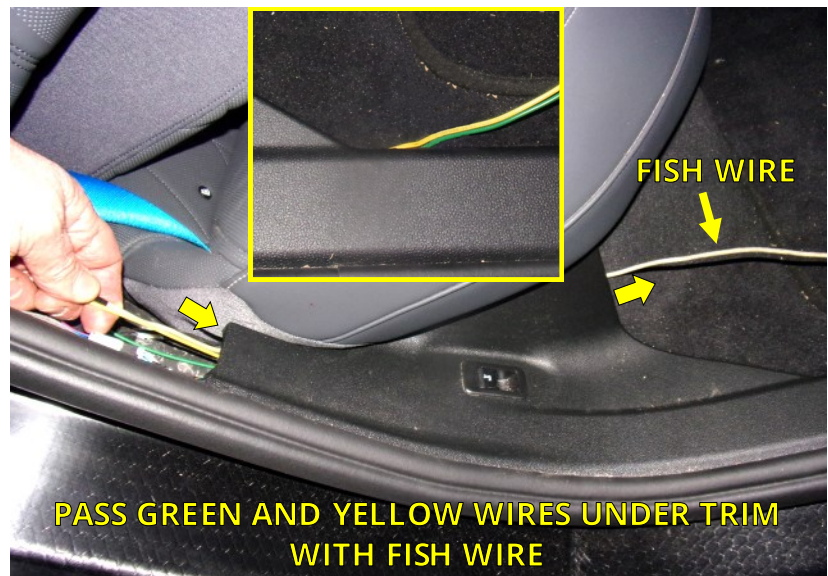
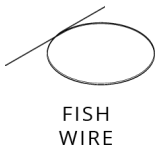

## INSTALL WIRING KIT CONTINUED



PLIERS



MULTIMETER

34. Route the green and yellow wires forward to the area where the passenger side door panel was removed in Step 30. Locate the indicated wire bundle. Use clamp-on connectors to connect the yellow and green wires to the left and right turn signal wires (see reference table below).

**NOTE:** Vehicles may have multiple wires with the same color or different wire colors than those shown. Verify circuits (wire colors) with multimeter.

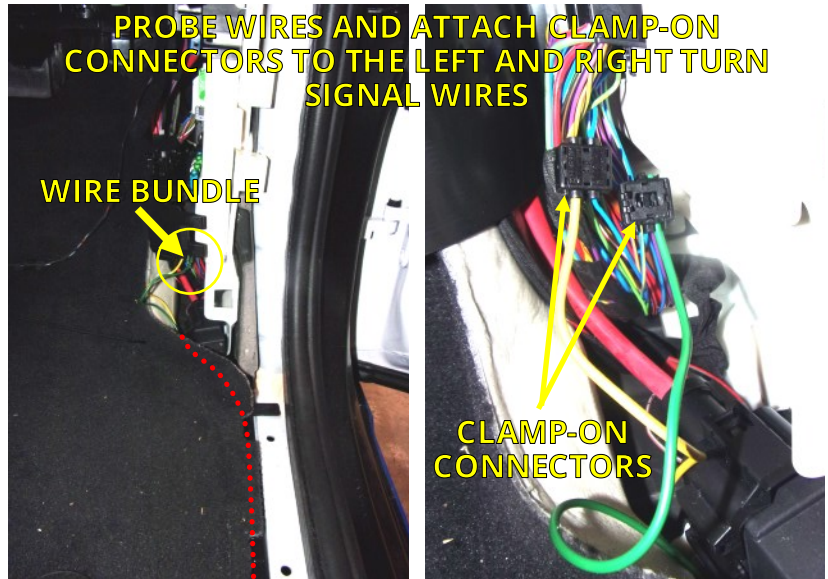

### CLAMP-ON CONNECTOR COLOR REFERENCE TABLE

SIGNAL INPUT WIRES			POWER & GROUND WIRES		
FUNCTION	HARNESS	VEHICLE			
<u>LEFT TURN</u>	YELLOW	BLUE	<u>12V+ (POWER)</u>	BLACK	FUSE TERMINAL (+)
<u>RIGHT TURN</u>	GREEN	BLUE/YELLOW	<u>GROUND</u>	WHITE	GROUND NUT
<u>MARKER</u>	BROWN	GREY/BROWN			
<u>BRAKE</u>	RED	BLACK/YELLOW			
<u>REVERSE</u>	PURPLE	For use with trailer reverse lights or to disable the trailer brakes when backing with surge brakes. To connect, isolate vehicle's reverse light circuit and connect the purple wire from the trailer wiring harness to vehicle reverse light circuit. <b>Trailers rarely have reverse lights or surge brakes.</b>			
<u>ELECTRIC BRAKE</u>	BLUE	Only used when a hard wired brake controller is mounted inside the vehicle and your trailer has electric brakes. See brake controller instructions for this wire.			

**NOTE:** If two colors are listed, the first color is the dominant color.



PLASTIC PRY TOOLS

35. With the yellow and green wire's connected, tuck the length of green and yellow wire that is visible in the front passenger and rear passenger areas under the trim where possible. No wire should be visible when the removed plastic trim pieces are replaced in a later step.

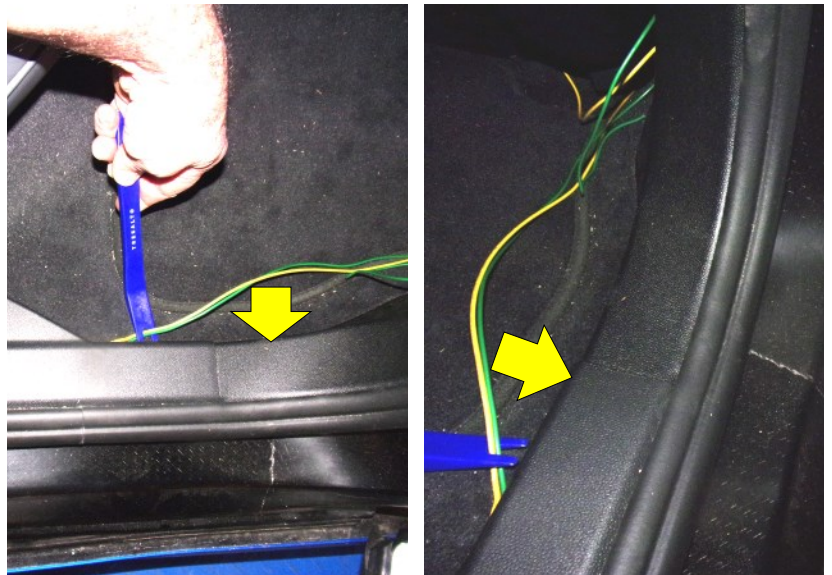

## INSTALL WIRING KIT CONTINUED

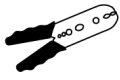

STRIPPER/  
CRIMPING  
TOOL

36. Inside the wall of the passenger side cargo compartment, locate the loose ends of the green and yellow wires and the green and yellow input wires of the control module. Trim the wires to length. Attach each similar color wire to each other using a red butt connector and crimping tool.

**NOTICE (OPTIONAL):** The butt connectors are heat shrink connectors. Apply heat to waterproof the connectors after crimping.

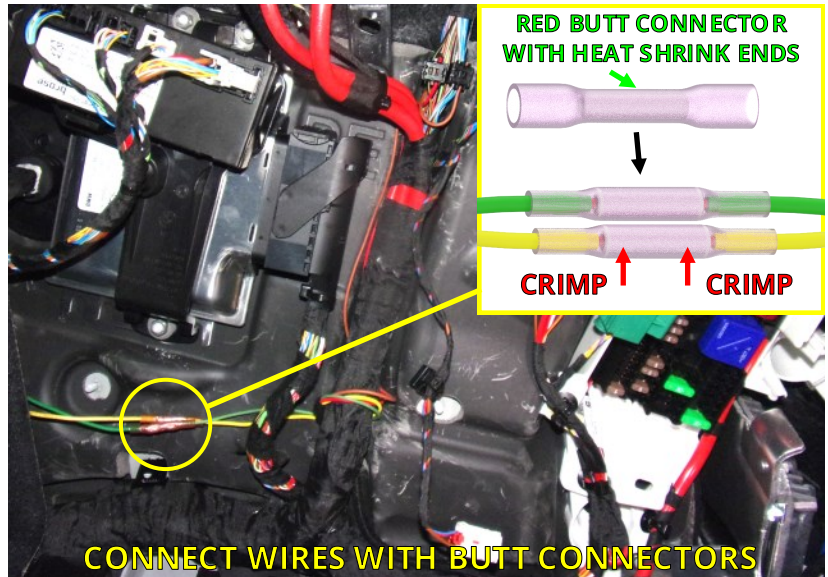

PLIERS



MULTIMETER

37. Inside the wall of the passenger side cargo compartment, locate the indicated wire bundle. Route the red and brown wires to the wire bundle location. Trim the red and brown wires to length and use clamp-on connectors to connect the red and brown wires to the brake and marker signal wires (see reference table on the previous page).

**NOTE:** Vehicles may have multiple wires with the same color or different wire colors than those shown. Verify circuits (wire colors) with multimeter.

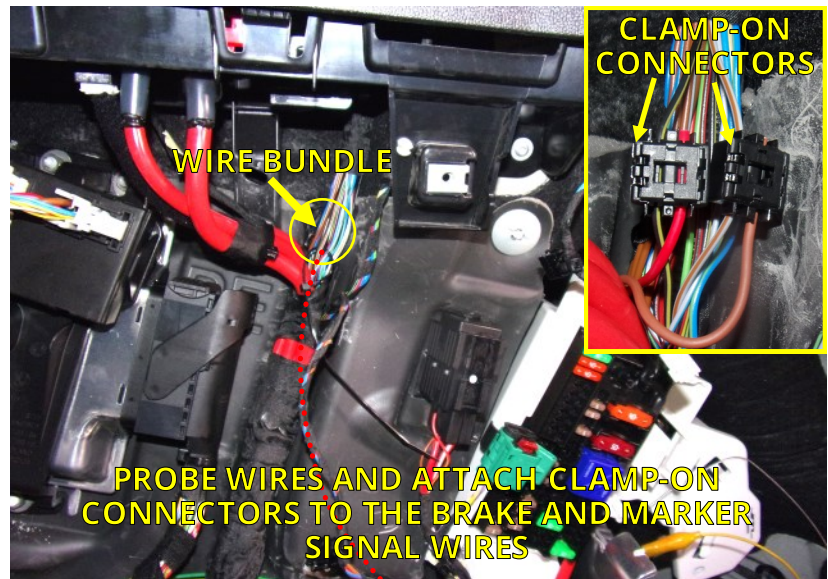

PLASTIC  
PRY TOOLS

38. Locate the fuse panel on the passenger side of the cargo compartment. Use a plastic pry tool to pry open the two clips at the top of the panel. Pull the panel away from the white plastic housing to gain access to the back of the panel. Locate and open the power terminal cover on the back of the fuse panel.

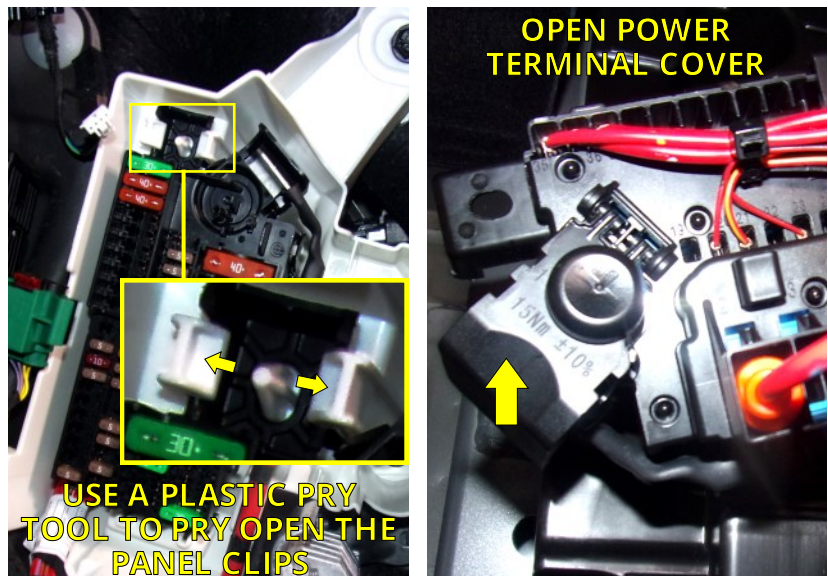

## INSTALL WIRING KIT CONTINUED

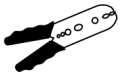

STRIPPER/  
CRIMPING  
TOOL



10mm  
SOCKET

39. Locate the fuse holder supplied in the wiring kit box. Remove the fuse from fuse holder. Locate the black power input wire connected to the control module. Trim excess power wire length. Crimp fuse lead to power wire. Use the supplied M8 nut to connect fuse ring terminal to the power terminal (+).

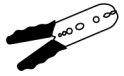
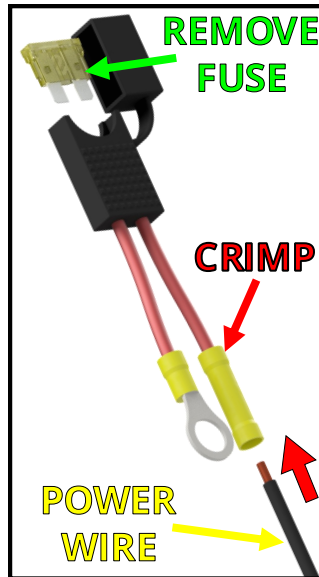

STRIPPER/  
CRIMPING  
TOOL



10mm  
SOCKET

40. Replace the fuse panel back into the housing with the fuse holder still accessible, see image.

41. Locate the ground stud next to the fuse panel. Trim the control module white ground input wire so it will reach stud without excess wire. Crimp supplied fork terminal to the ground wire with a crimping tool. Loosen the ground stud and secure the fork to the stud.

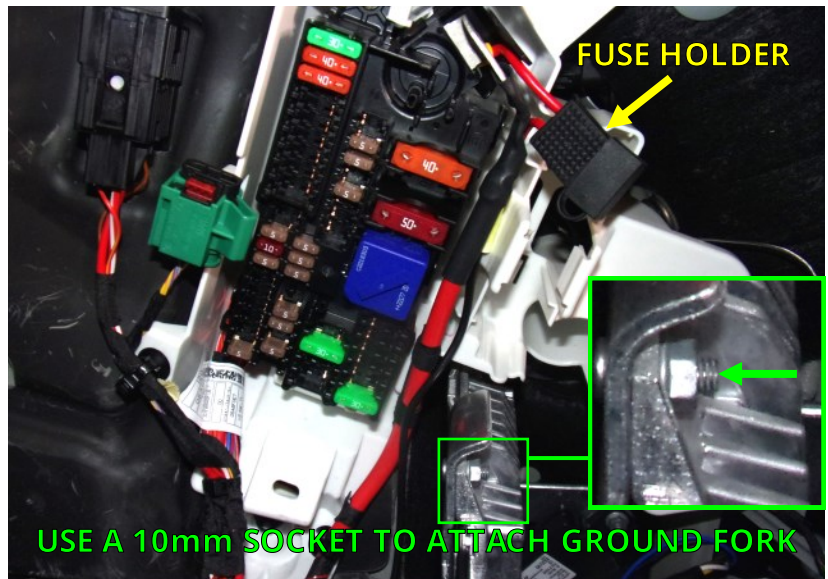

PHILLIPS HEAD  
SCREWDRIVER

42. Locate the 7-way housing. Use a screwdriver to loosen (2) screws. Remove 7-way round terminal block. Place the mounting bracket onto the 7-way housing as shown. Use a screwdriver to loosen the set screw at the bottom of the 7-way housing. Route output side wires of the wiring harness through the 7-way housing.

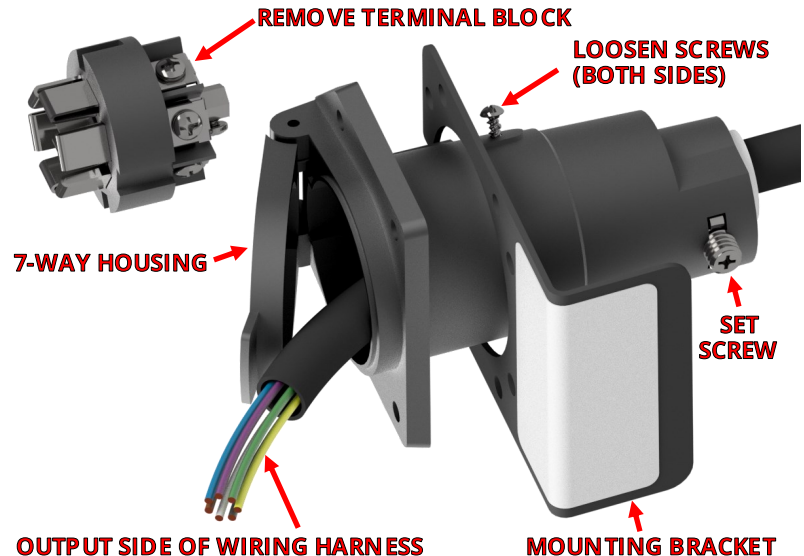



## INSTALL WIRING KIT CONTINUED

**Please follow instructions below very carefully.**  
**Incorrect wiring of the 7-way receptacle causes the vast majority of wiring problems.**



PHILLIPS HEAD  
SCREWDRIVER



STRIPPER/  
CRIMPING  
TOOL

43. Locate the slot keyway. Starting from the keyway going **clockwise**, attach the wires as follows:

- Blue
- Green
- Black
- Brown
- Yellow
- White
- Purple (middle)

***NOTICE: Markings on the receptacle may not match the correct wire configuration. Please disregard and follow the instruction above.***

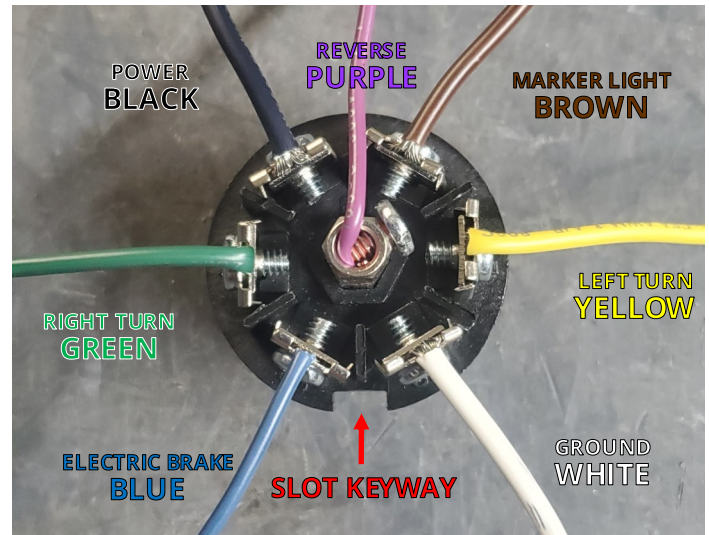

## TEST 7-WAY HARNESS WIRING



PHILLIPS HEAD  
SCREWDRIVER



MULTIMETER

44. Put the 7-way receptacle back together. While everything is still accessible, you should test the wiring to make sure everything is connected properly and in working order. **Replace the 20 Amp fuse into the fuse holder located near the fuse panel.**

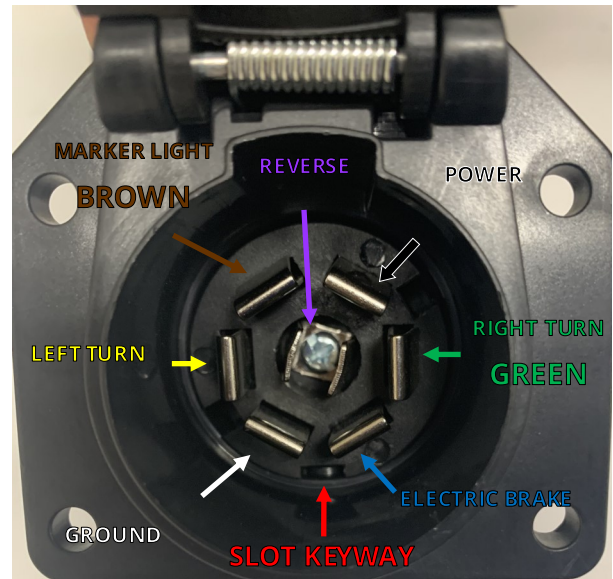

- Start by connecting the multimeter negative probe to the ground blade on the 7-way receptacle.
- Next, connect the multimeter positive probe to the power blade on the 7-way receptacle and check for 12 volts.
- Once that is confirmed, move the positive probe to the left turn blade on the 7-way receptacle and check for 12 volts when the vehicle left turn blinker is active. You should see it pulse.
- Next, move the positive probe to the right turn blade and check for 12 volts when the right turn blinker is active. You should see it pulse.
- Next, move the positive probe to the marker/taillights. With the vehicle lights on you should see 12 volts constant.
- Lastly, with the brake depressed, move the positive probe to the left turn blade where you should see 12 volts constant. Move the probe to the right turn blade where you should also see 12 volts constant.

## INSTALL WIRING KIT CONTINUED



PHILLIPS HEAD  
SCREWDRIVER



SILICONE

45. Carefully pass the wire of the 7-way housing through the mounting bracket. Attach the 7-way housing to the Stealth hitch frame as shown. Secure harness to Stealth hitch frame with cable ties provided in the wiring kit.

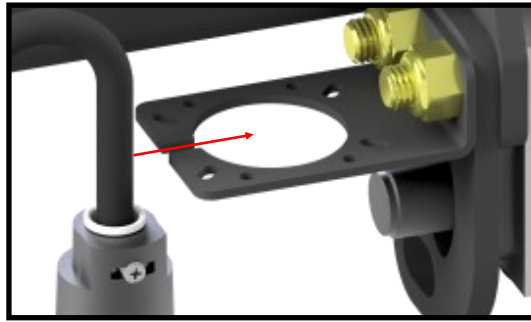

**PASSENGER  
SIDE**

46. Secure all wires and wiring components. Use the remaining wiring kit cable ties to secure wiring so that it is not loose and will not interfere with replacement of the fascia. Wiring should not be visible once the vehicle is reassembled.

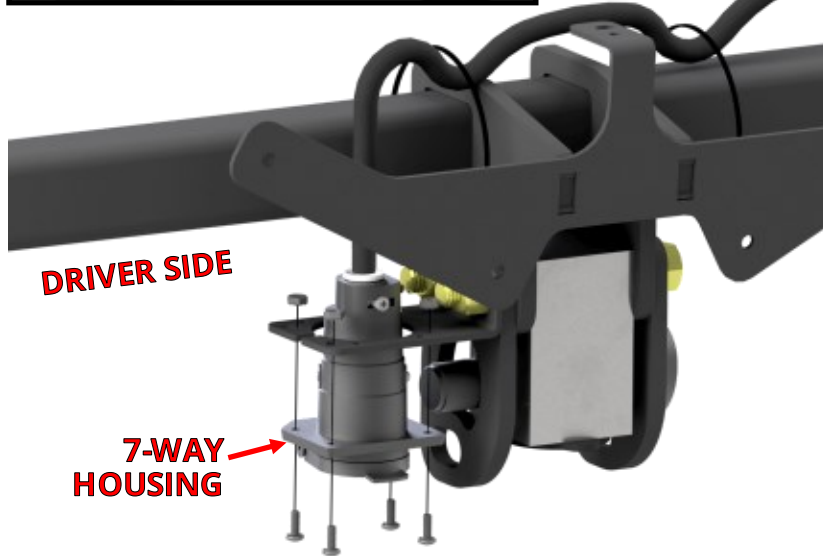

**DRIVER SIDE**

**7-WAY  
HOUSING**

47. Use the provided adhesive foam strips to secure the control module to an inside body panel. Use silicone to waterproof grommet.

48. Reattach any passenger side trim pieces, wall panels, wired connectors, and other components removed when installing the tow kit in reverse order. Refer to Steps 18-31.

## PREPARE FASCIA



DREMEL TOOL



FILE

49. Cut out a section of the rear fascia with a Dremel tool as shown in the image. Use a file to smooth the edges of the cut.

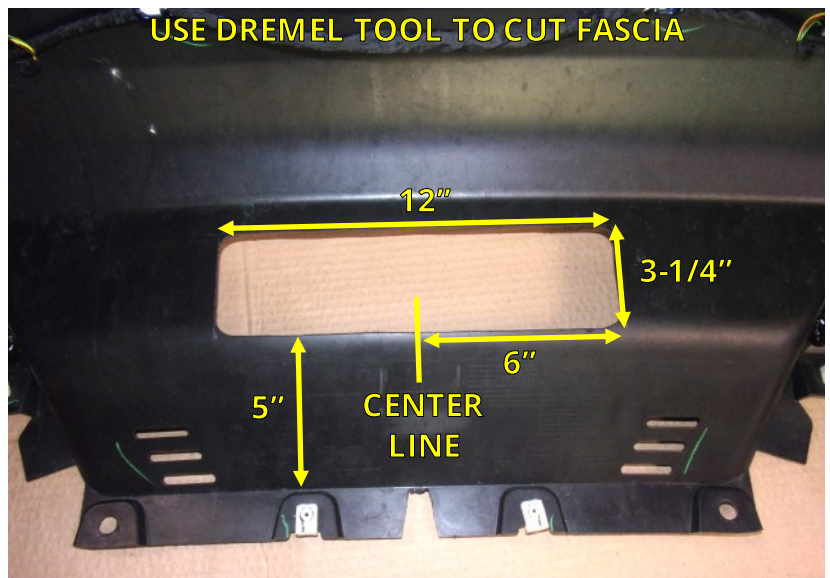

## REINSTALL VEHICLE COMPONENTS

50. Reattach and secure the fascia, underbody panels and other vehicle components in reverse order. Refer to Steps 1-8.

***NOTICE: It's important to remember to plug in the sensor before you completely install the fascia.***



51. Finished view.



## FINAL VEHICLE EXAMINATION

52. Examine the body panels to ensure that they are in a pre-installation condition. Test the electronic functions of the vehicle. Correct any inconsistencies.
53. Ensure that hitch components work properly.
  - **Verify that the lock works correctly.** Push in the safety lock on the latch block then unlock with key. The lock should slide back out with the key when unlocked.
  - **Verify that each accessory can be installed correctly.** Use the following steps to install and remove each accessory that will be used with the hitch. (*Rack Receiver* and *Ball Mount* if purchased.)
    1. Prepare latching mechanism. Turn handle clockwise if needed.
    2. Firmly insert "post" of accessory into latch block until handle releases indicating that the accessory is latched.
    3. Push in the safety locking pin until it fully engages. The locking pin prevents the handle from turning when pushed in, and confirms that the block is securely latched onto the accessory. The safety locking pin will not depress if the accessory is not fully latched.
    4. Use key to release safety locking pin.
    5. While holding on to the accessory, rotate handle clockwise to release and remove the accessory.
  - **Verify that no part of the accessories come into contact with the body of the vehicle.**

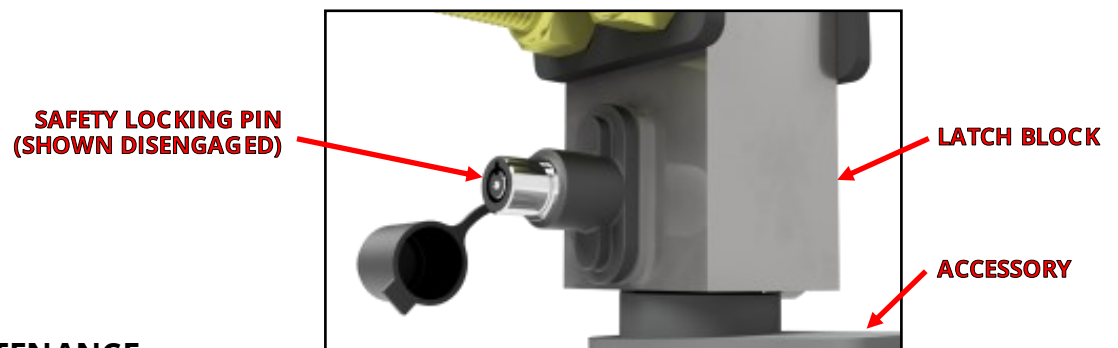

## PRODUCT USE AND MAINTENANCE

**NOTICE: If the hitch is being installed by a professional, the installer is responsible for training the end user in the use and maintenance of the product.**

- **Accessory installation procedure:**
  1. Prepare latching mechanism. Turn handle clockwise if needed.
  2. Firmly insert "post" of accessory into latch block until handle spins counter-clockwise indicating that the accessory is latched.
  3. Always depress the safety locking pin and check that it has fully engaged.
- **Never use any accessory with the safety lock disengaged.** Until the safety locking pin is engaged, the handle is able to turn. A fully engaged safety locking pin is confirmation that the accessory is properly latched into the latch block.
- **Never use the rack receiver for towing.** The rack receiver accessory is only to be used with payload carrying products, such as bike racks or luggage racks.
- **Before each use, give the post of the accessory a light coating of lithium based grease.**
- **Before each use, inspect the hitch to ensure that all bolted connections are secure and that no cracks or damage are present.** Do not tow with the hitch if cracks or damage outside of normal wear is found.
- **Remove the Stealth accessories from the latch block after each use.** Do not leave accessories plugged in for extended periods of time.

SHR31040\_(pn 2120-31040-2) 03 10 2023